



**DEPARTMENT OF REGULATORY AND ECONOMIC RESOURCES (RER)
BOARD AND CODE ADMINISTRATION DIVISION
NOTICE OF ACCEPTANCE (NOA)**

**MIAMI-DADE COUNTY
PRODUCT CONTROL SECTION**
11805 SW 26 Street, Room 208
Miami, Florida 33175-2474
T (786) 315-2590 F (786) 315-2599
www.miamidade.gov/economy

**DAB Door Company, Inc.
12195 NW 98th Avenue
Hialeah Gardens, FL 33018**

SCOPE:

This NOA is being issued under the applicable rules and regulations governing the use of construction materials. The documentation submitted has been reviewed and accepted by Miami-Dade County RER-Product Control Section to be used in Miami-Dade County and other areas where allowed by the Authority Having Jurisdiction (AHJ).

This NOA shall not be valid after the expiration date stated below. The Miami-Dade County Product Control Section (In Miami-Dade County) and/or the AHJ (in areas other than Miami-Dade County) reserve the right to have this product or material tested for quality assurance purposes. If this product or material fails to perform in the accepted manner, the manufacturer will incur the expense of such testing and the AHJ may immediately revoke, modify, or suspend the use of such product or material within their jurisdiction. RER reserves the right to revoke this acceptance, if it is determined by Miami-Dade County Product Control Section that this product or material fails to meet the requirements of the applicable building code.

This product is approved as described herein and has been designed to comply with the Florida Building Code, including the High Velocity Hurricane Zone.

DESCRIPTION: Model 924 Steel Sectional Garage Door up to 12ft.-4in. Wide x 18ft. High

APPROVAL DOCUMENT: Drawing No. **04-01**, titled “Steel Overhead Sectional Garage Door”, dated 01/16/2004, with last revision **H** dated 07/20/2020, sheets 1 through 5 of 5, prepared by Al-Farooq Corporation, signed and sealed by Jalal Farooq, P.E., bearing the Miami-Dade County Product Control revision stamp with the Notice of Acceptance number and expiration date by the Miami-Dade County Product Control Section.

MISSILE IMPACT RATING: Large and Small Missile Impact Resistant

LABELING: A permanent label with the manufacturer’s name or logo, manufacturing address, model number, the positive and negative design pressure rating, indicate impact rated if applicable, installation instruction drawing reference number, approval number (NOA), the applicable test standards, and the statement reading ‘Miami-Dade County Product Control Approved’ is to be located on the door’s side track, bottom angle, or inner surface of a panel.

LIMITATION: This door has not been tested for air infiltration.

RENEWAL of this NOA shall be considered after a renewal application has been filed and there has been no change in the applicable building code negatively affecting the performance of this product.

TERMINATION of this NOA will occur after the expiration date or if there has been a revision or change in the materials, use, and/or manufacture of the product or process. Misuse of this NOA as an endorsement of any product, for sales, advertising or any other purposes shall automatically terminate this NOA. Failure to comply with any section of this NOA shall be cause for termination and removal of NOA.

ADVERTISEMENT: The NOA number preceded by the words Miami-Dade County, Florida, and followed by the expiration date may be displayed in advertising literature. If any portion of the NOA is displayed, then it shall be done in its entirety.

INSPECTION: A copy of this entire NOA shall be provided to the user by the manufacturer or its distributors and shall be available for inspection at the job site at the request of the Building Official.

This NOA revises NOA # **20-0107.07** and consists of this page 1 and evidence pages E-1, E-2, E-3 and E-4, as well as approval document mentioned above.

The submitted documentation was reviewed by **Carlos M. Utrera, P.E.**



**NOA No. 20-0901.23
Expiration Date: July 14, 2025
Approval Date: December 03, 2020
Page 1**

NOTICE OF ACCEPTANCE: EVIDENCE SUBMITTED

1. EVIDENCE SUBMITTED UNDER PREVIOUS NOA's

A. DRAWINGS “Submitted under NOA # 15-0317.06”

1. Drawing No. **04-01**, titled “Steel Overhead Sectional Garage Door”, dated 01/16/2004, with last revision **F** dated 03/09/2015, sheets 1 through 5 of 5, prepared by Al-Farooq Corporation, signed and sealed by Javad Ahmad, P.E.

B. TESTS “Submitted under NOA # 05-0217.01”

1. Test Report on Large Missile Impact Test per FBC, TAS 201-94 and Cyclic Wind Pressure Test per FBC, TAS 203-94, of “Sectional Residential Door” prepared by Hurricane Engineering & Testing Inc. Report No. **HETI 03-1868**, dated 11/12/2003, signed and sealed by R. E. Droz-Seda, P.E.
2. Test Report on Uniform Static Air Pressure Test per FBC TAS 202-94, “Sectional Residential Door” prepared by Hurricane Engineering & Testing Inc., Report No. **HETI 03-1865**, dated 10/24/2003, signed and sealed by R. E. Droz-Seda, P.E.
3. Test Report on Tensile Test per ASTM E-8 of “Sectional Commercial Overhead Door (skin)” prepared by Hurricane Engineering & Testing Inc, Report No. **HETI 04-T098**, dated 01/08/2004, signed and sealed by R. E. Droz-Seda PE.

C. CALCULATIONS “Submitted under NOA # 14-1014.13”

1. Anchoring verification calculations prepared by Al-Farooq Corporation, dated 09/11/2014, signed and sealed by Javad Ahmad, P.E.

“Submitted under NOA # 09-0324.05”

2. Anchor verification calculations prepared by Al-Farooq Corporation, complying with F.B.C 2007, dated 01/21/2009, signed and sealed by Humayoun Farooq, P.E.

D. QUALITY ASSURANCE

1. Miami-Dade Department of Regulatory and Economic Resources (RER)



Carlos M. Utrera, P.E.
Product Control Examiner
NOA No. 20-0901.23
Expiration Date: July 14, 2025
Approval Date: December 12, 2020

NOTICE OF ACCEPTANCE: EVIDENCE SUBMITTED

E. MATERIAL CERTIFICATIONS

1. Notice of Acceptance No. **14-0311.08**, issued to Insulfoam, LLC, for their Insulfoam Expanded Polystyrene Insulation, approved on 08/14/2014 and expiring on 11/29/2017.
2. Notice of Acceptance No. **11-0926.07**, issued to Dyplast Products, LLC, for their Expanded Polystyrene Block Type Insulation, approved on 11/10/2011 and expiring on 01/11/2017.
3. Notice of Acceptance No. **11-0926.06**, issued to Dyplast Products, LLC, for their Dyplast ISO-C1 Polyisocyanurate Insulation, approved on 11/10/2011 and expiring on 01/11/2017.

“Submitted under NOA # 05-0217.01”

4. Tensile Test Report No. **HETI 01-T006**, prepared by Hurricane Engineering & Testing, Inc. dated 01/30/2001, signed and sealed by H.M. Medina, P.E.

F. STATEMENTS *“Submitted under NOA # 14-1014.13”*

1. Statement letter of code conformance to 5th edition (2014) FBC and no financial interest issued by Al-Farooq Corporation, dated 09/23/2014, signed and sealed by Javad Ahmad, P.E.

“Submitted under NOA # 12-0110.09”

2. Statement letter of code conformance to 2010 FBC and no financial interest issued by Al-Farooq Corporation, dated 10/26/2011, signed and sealed by Javad Ahmad, P.E.



Carlos M. Utrera, P.E.
Product Control Examiner
NOA No. 20-0901.23
Expiration Date: July 14, 2025
Approval Date: December 12, 2020

DAB Door Company, Inc.

NOTICE OF ACCEPTANCE: EVIDENCE SUBMITTED

2. EVIDENCE SUBMITTED IN PREVIOUS NOA # 20-0107.07

A. DRAWINGS

1. Drawing No. **04-01**, titled “Steel Overhead Sectional Garage Door”, dated 01/16/2004, with last revision **G** dated 10/31/2017, sheets 1 through 5 of 5, prepared by Al-Farooq Corporation, signed and sealed by Javad Ahmad, P.E.

B. TESTS

1. None.

C. CALCULATIONS

1. None.

D. QUALITY ASSURANCE

1. Miami-Dade Department of Regulatory and Economic Resources (RER)

E. MATERIAL CERTIFICATIONS

1. Notice of Acceptance No. **17-0221.06**, issued to Insulfoam, LLC, a Div. of Carlisle Const. Materials, for their Insulfoam Expanded Polystyrene Insulation, approved on 06/01/2017 and expiring on 11/29/2022.
2. Notice of Acceptance No. **16-1129.05**, issued to Dyplast Products, LLC, for their Expanded Polystyrene Block Type Insulation, approved on 01/19/2017 and expiring on 01/11/2022.
3. Notice of Acceptance No. **16-1108.04**, issued to Dyplast Products, LLC, for their Dyplast ISO-C1 Polyisocyanurate Insulation, approved on 01/19/2017 and expiring on 01/11/2022.

F. STATEMENTS

1. Statement letter of code conformance to the 6th edition (2017) FBC, prepared by Al Farooq Corporation, dated 12/23/2019, signed and sealed by Javad Ahmad, P.E.



Carlos M. Utrera, P.E.
Product Control Examiner
NOA No. 20-0901.23
Expiration Date: July 14, 2025
Approval Date: December 12, 2020

NOTICE OF ACCEPTANCE: EVIDENCE SUBMITTED

3. NEW EVIDENCE SUBMITTED.

A. DRAWINGS

1. Drawing No. **04-01**, titled “Steel Overhead Sectional Garage Door”, dated 01/16/2004, with last revision **H** dated 07/20/2020, sheets 1 through 5 of 5, prepared by Al-Farooq Corporation, signed and sealed by Jalal Farooq, P.E.

B. TESTS

1. None.

C. CALCULATIONS

1. None.

D. QUALITY ASSURANCE

1. Miami Dade Department of Regulatory and Economic Resources (RER).

E. MATERIAL CERTIFICATIONS

1. None.

F. STATEMENTS

1. Letter of conformance to FBC 2020 (7th Edition) and FBC 2017 (6th Edition), prepared by Al Farooq Corporation, dated 07/31/2020, signed and sealed by Jalal Farooq, P.E.



Carlos M. Utrera, P.E.
Product Control Examiner
NOA No. 20-0901.23
Expiration Date: July 14, 2025
Approval Date: December 12, 2020

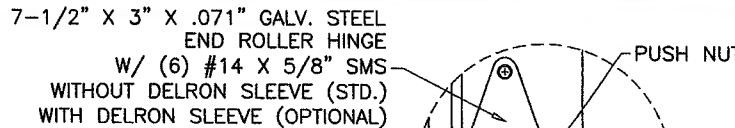
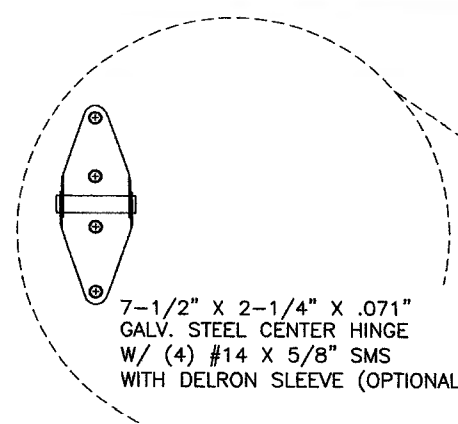

PRODUCT REVISED
 as complying with the Florida
 Building Code
 NOA-No. 20-0901.23
 Expiration Date 07/14/2025
 By *[Signature]*
 Miami-Dade Product Control

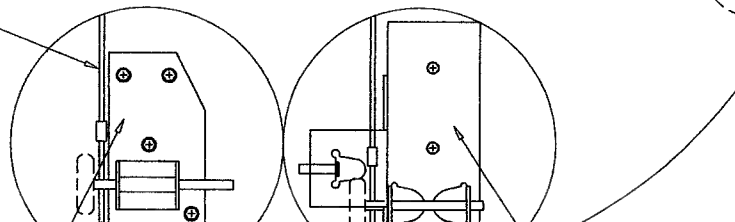
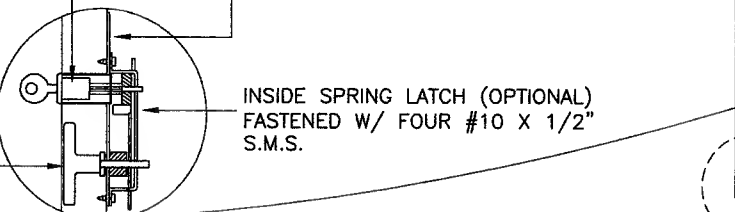
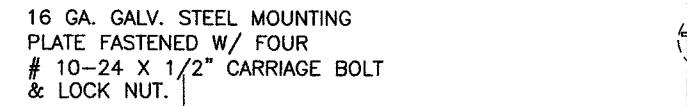
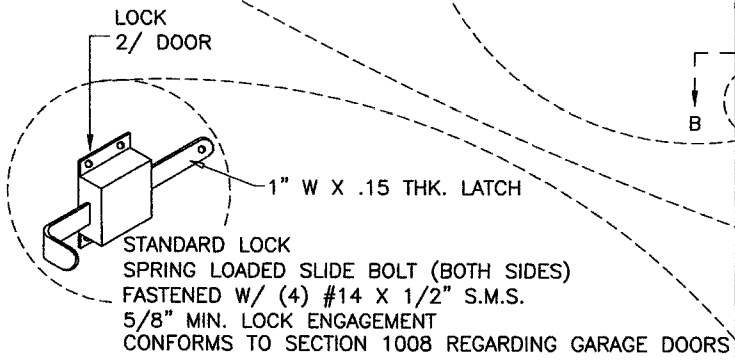

DOOR HEIGHT	CONSISTS OF	TOTAL # OF 'U' BARS AT EACH DOOR
7'	4 SECTIONS 21"	5
7'-6"	2 SECTIONS 24" 2 SECTIONS 21"	
7'-9"	3 SECTIONS 24" 1 SECTION 21"	
8'	4 SECTIONS 24"	
8'-9"	5 SECTIONS 21"	6
9'	1 SECTION 24" 4 SECTIONS 21"	
9'-6"	3 SECTIONS 24" 2 SECTIONS 21"	
9'-9"	4 SECTIONS 24" 1 SECTION 21"	
10'	5 SECTIONS 24"	7
10'-6"	6 SECTIONS 21"	
10'-9"	1 SECTION 24" 5 SECTIONS 21"	
11'	2 SECTIONS 24" 4 SECTIONS 21"	
11'-6"	4 SECTIONS 24" 2 SECTIONS 21"	8
11'-9"	5 SECTIONS 24" 1 SECTION 21"	
12'	6 SECTIONS 24"	
12'-6"	1 SECTION 24" 6 SECTIONS 21"	
12'-9"	2 SECTIONS 24" 5 SECTIONS 21"	9
13'	3 SECTIONS 24" 4 SECTIONS 21"	
13'-6"	5 SECTIONS 24" 2 SECTIONS 21"	
13'-9"	6 SECTIONS 24" 1 SECTION 21"	
14'	7 SECTIONS 24"	10
14'-6"	2 SECTION 24" 6 SECTIONS 21"	
14'-9"	3 SECTIONS 24" 5 SECTIONS 21"	
15'	4 SECTIONS 24" 4 SECTIONS 21"	
15'-6"	6 SECTIONS 24" 2 SECTIONS 21"	10
15'-9"	7 SECTIONS 24" 1 SECTION 21"	
16'	8 SECTIONS 24"	
16'-6"	3 SECTION 24" 6 SECTIONS 21"	
16'-9"	4 SECTIONS 24" 5 SECTIONS 21"	10
17'	5 SECTIONS 24" 4 SECTIONS 21"	
17'-6"	7 SECTIONS 24" 2 SECTIONS 21"	
17'-9"	8 SECTIONS 24" 1 SECTION 21"	
18'	9 SECTIONS 24"	

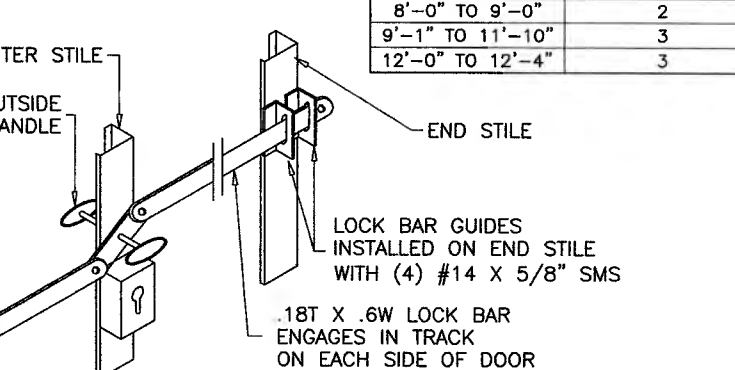
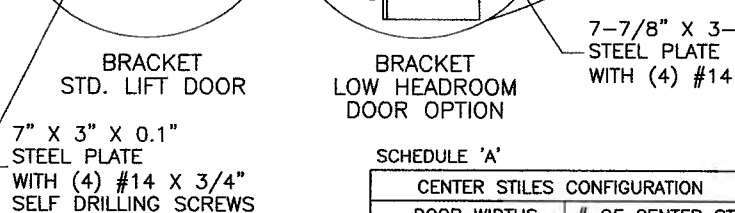

OUTSIDE KEYED LOCK (OPTIONAL)
 LOCK BAR LOCKING SHOWN
 ALTERNATE TO SPRING LOADED SLIDE BOLT
 LOCKS SHOWN ABOVE

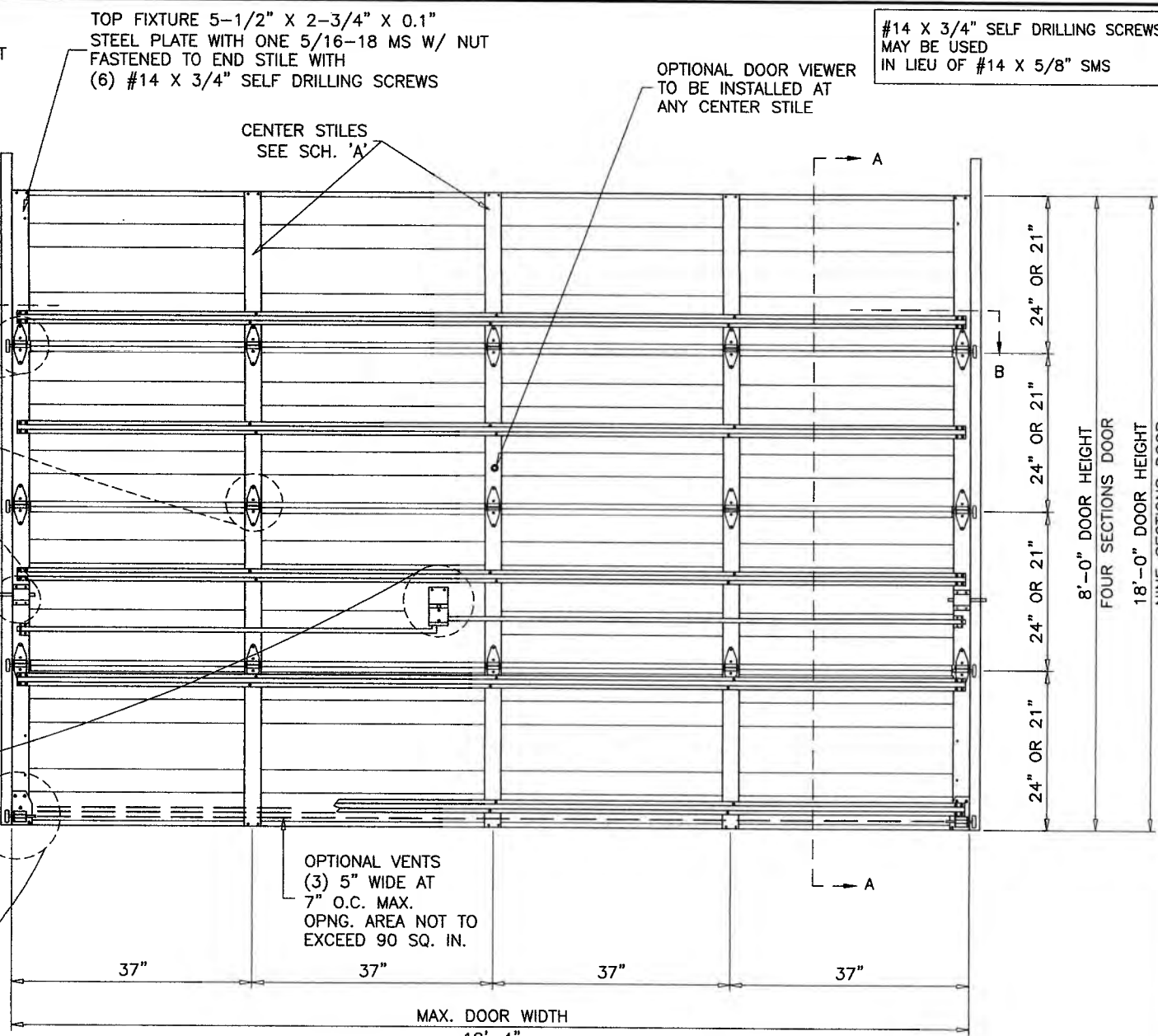

INSIDE ELEVATION
 THIS PRODUCT IS RATED FOR LARGE MISSILE IMPACT
DAB DOOR MODEL 924
 MAX. SIZE 12'-4" WIDE X 18'-0" HIGH
 24 GA. ROLL FORMED STEEL

- GENERAL NOTES**
- THIS PRODUCT HAS BEEN DESIGNED AND TESTED TO COMPLY WITH THE REQUIREMENTS OF THE 2017 (6TH EDITION)/2020 (7TH EDITION) FLORIDA BUILDING CODE INCLUDING HIGH VELOCITY HURRICANE ZONE (HVHZ).
 - ANCHORS SHALL BE CORROSION RESISTANT, SPACED AS SHOWN ON DETAILS AND INSTALLED PER MANUF'S INSTRUCTIONS. SPECIFIED EMBEDMENT TO BASE MATERIAL SHALL BE BEYOND WALL DRESSING OR STUCCO.
 - A LOAD DURATION INCREASE IS USED IN DESIGN OF ANCHORS INTO WOOD ONLY.
 - MATERIALS INCLUDING BUT NOT LIMITED TO STEEL/METAL SCREWS, THAT COME INTO CONTACT WITH OTHER DISSIMILAR MATERIALS SHALL MEET THE REQUIREMENTS OF THE 2017/2020 FLORIDA BLDG. CODE & ADOPTED STANDARDS.
 - THIS PRODUCT APPROVAL IS GENERIC AND DOES NOT PROVIDE INFORMATION FOR A SITE SPECIFIC PROJECT, I.E. LIFE SAFETY OF THIS PRODUCT, ADEQUACY OF STRUCTURE RECEIVING THIS PRODUCT AND SEALING AROUND OPENING FOR WATER INFILTRATION RESISTANCE ETC. CONDITIONS NOT SHOWN IN THIS DRAWING ARE TO BE ANALYZED SEPARATELY, AND TO BE REVIEWED BY BUILDING OFFICIAL.
 - MANUFACTURER'S LABEL SHALL BE LOCATED ON A READILY VISIBLE LOCATION IN ACCORDANCE WITH SECTION 1709.9.3 OF FLORIDA BUILDING CODE. LABELING TO COMPLY WITH SECTION 1709.9.2.

SCHEDULE 'A'

CENTER STILES CONFIGURATION	
DOOR WIDTHS	# OF CENTER STILES
8'-0" TO 9'-0"	2
9'-1" TO 11'-10"	3
12'-0" TO 12'-4"	3

DESIGN PRESSURE RATING = + 60.0 PSF
 - 65.0 PSF

NOV 16 2020

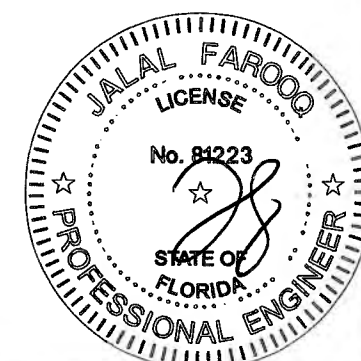

AL-FAROOQ CORPORATION
 ENGINEERS & PRODUCT DEVELOPMENT
 9360 SUNSET DRIVE, SUITE 220
 MIAMI, FLORIDA 33173 (C.A.N. 3538)
 TEL. (305) 264-8100 FAX. (305) 262-6978

STEEL OVERHEAD SECTIONAL GARAGE DOOR
DAB Door Company, Inc.
 12195 N.W. 98th Ave.
 Hialeah Gardens, FL 33018
 Tel: (800) 257-2016 Fax: (305) 362-9272

revisions:

no.	date	description
D	10.13.11	UPDATED TO 2010 FBC
E	09.16.14	GENERAL REVISION
F	03.09.15	NO CHANGE THIS SHEET
G	10.31.17	UPDATED TO 2017 FBC
H	07.20.20	UPDATED TO 2020 FBC

date: 01-16-04
 scale: 1/2"=1'-0"
 dr. by: TARIQ
 chk. by:

drawing no.
04-01
 sheet 1 of 5

GARAGE\04-01DAB

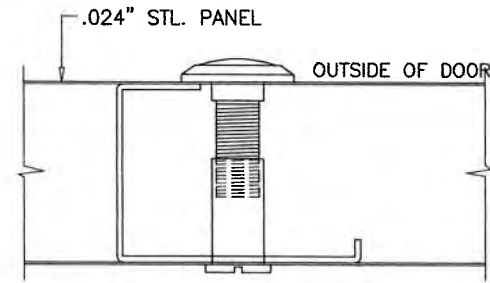

SOLID BRASS DOOR VIEWER
 BY 'SCHLAGE SECURITY HARDWARE'
 INSTALLED IN 9/16" DIA. HOLES IN CENTER STILE
 POSITIONED AT EYE LEVEL

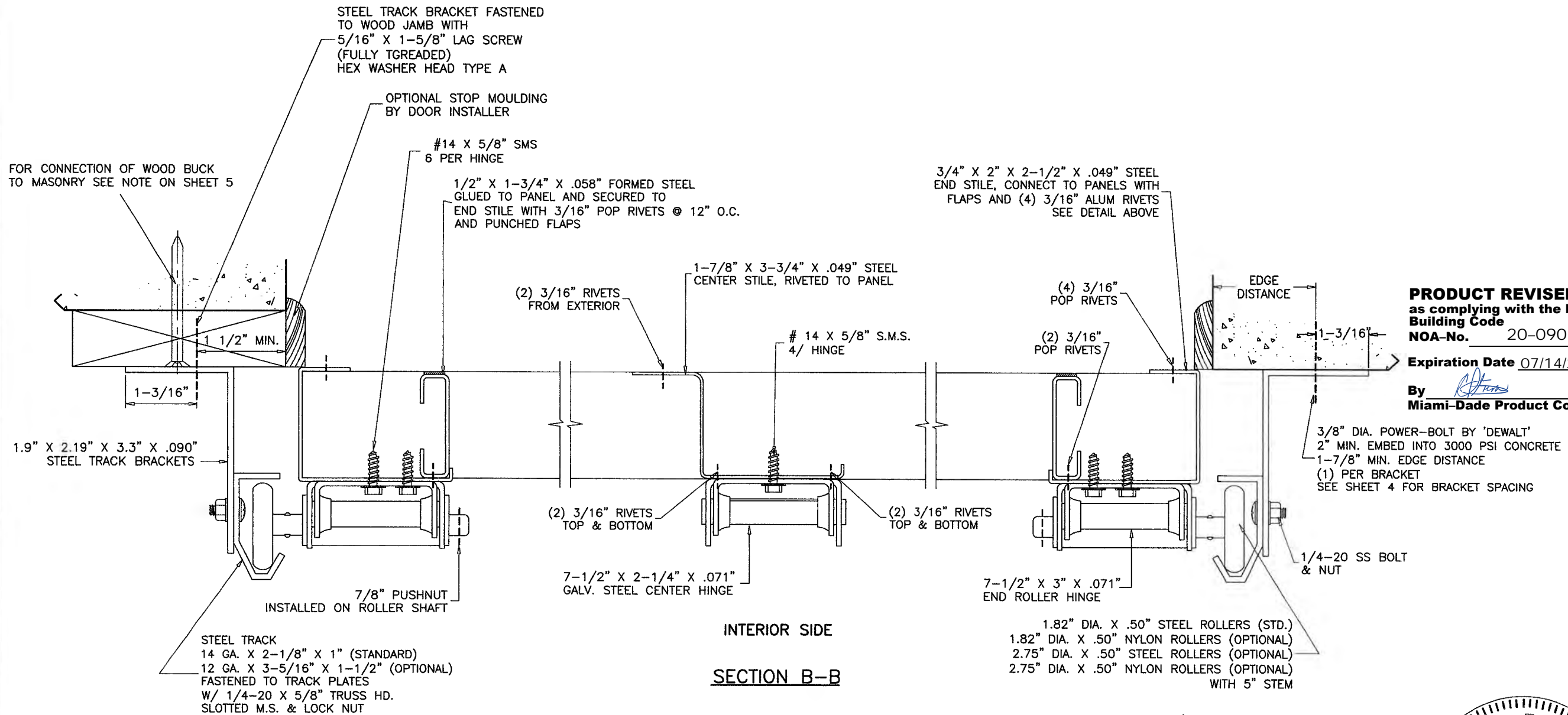

PRODUCT REVISED
 as complying with the Florida
 Building Code
 NOA-No. 20-0901.23
 Expiration Date 07/14/2025
 By *[Signature]*
 Miami-Dade Product Control

3/8" DIA. POWER-BOLT BY 'DEWALT'
 2" MIN. EMBED INTO 3000 PSI CONCRETE
 1-7/8" MIN. EDGE DISTANCE
 (1) PER BRACKET
 SEE SHEET 4 FOR BRACKET SPACING

1.82" DIA. X .50" STEEL ROLLERS (STD.)
 1.82" DIA. X .50" NYLON ROLLERS (OPTIONAL)
 2.75" DIA. X .50" STEEL ROLLERS (OPTIONAL)
 2.75" DIA. X .50" NYLON ROLLERS (OPTIONAL)
 WITH 5" STEM

INTERIOR SIDE
SECTION B-B

NOV 16 2020

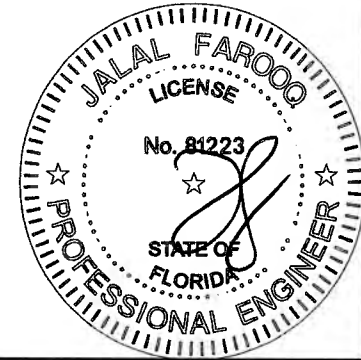

afC
AL-FAROOQ CORPORATION
 ENGINEERS & PRODUCT DEVELOPMENT
 9360 SUNSET DRIVE, SUITE 220
 MIAMI, FLORIDA 33173 (C.A.N. 3538)
 TEL. (305) 264-8100 FAX. (305) 262-6978
 GARAGE\04-01DAB

STEEL OVERHEAD SECTIONAL GARAGE DOOR
DAB Door Company, Inc.
 12195 N.W. 98th Ave.
 Hialeah Gardens, FL 33018
 Tel: (800) 257-2016 Fax: (305) 362-9272

no	date	by	description
D	10.13.11		NO CHANGE THIS SHEET
E	09.16.14		GENERAL REVISION
F	03.09.15		NO CHANGE THIS SHEET
G	10.31.17		UPDATED TO 2017 FBC
H	07.20.20		UPDATED TO 2020 FBC

date: 01-16-04
 scale: -
 dr. by: TARIQ
 chk. by:

drawing no.
04-01
 sheet 2 of 5

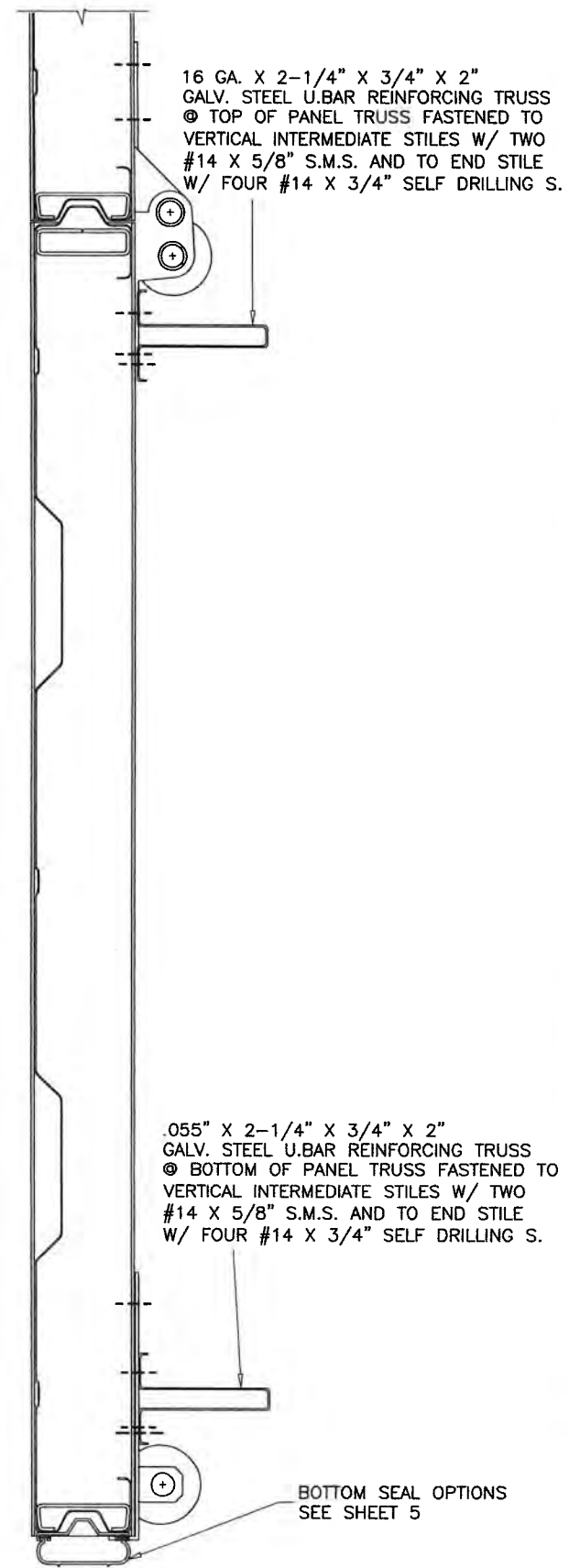

BOTTOM PANEL
REINFORCING

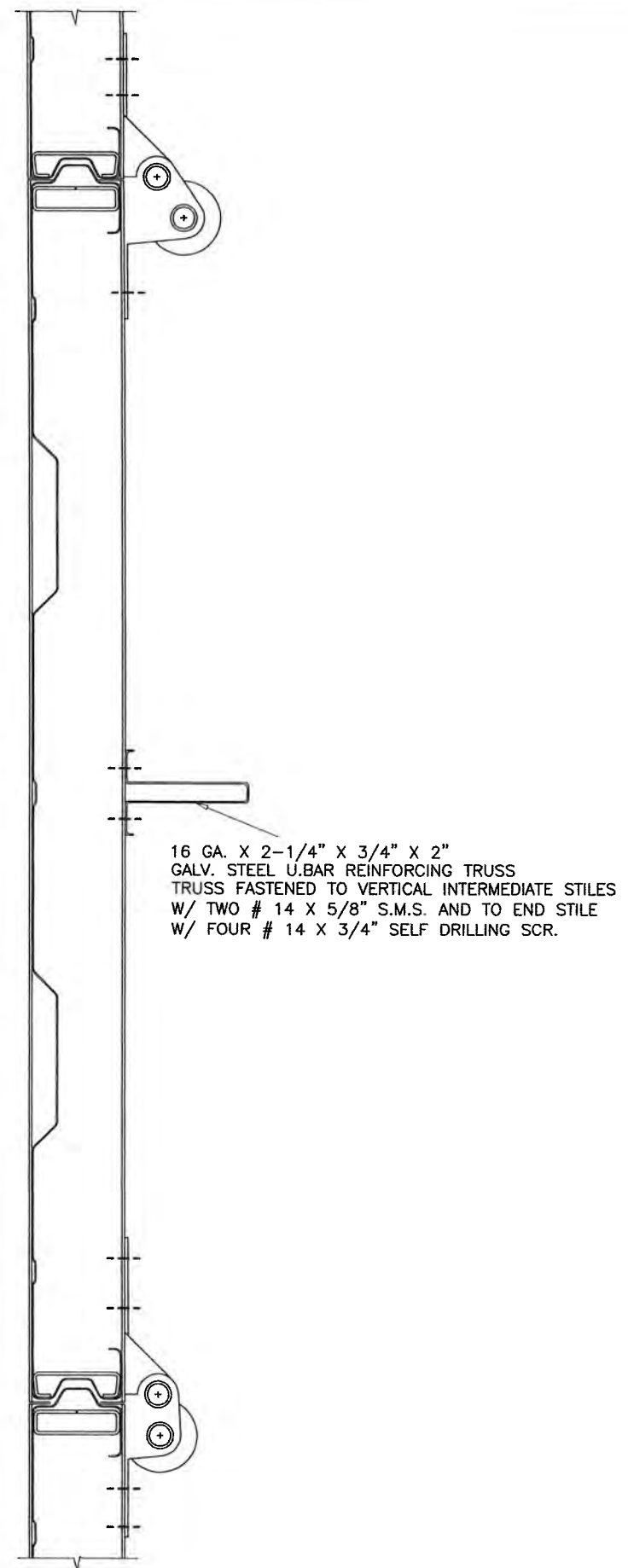

ALL INTERMEDIATE PANELS
REINFORCING

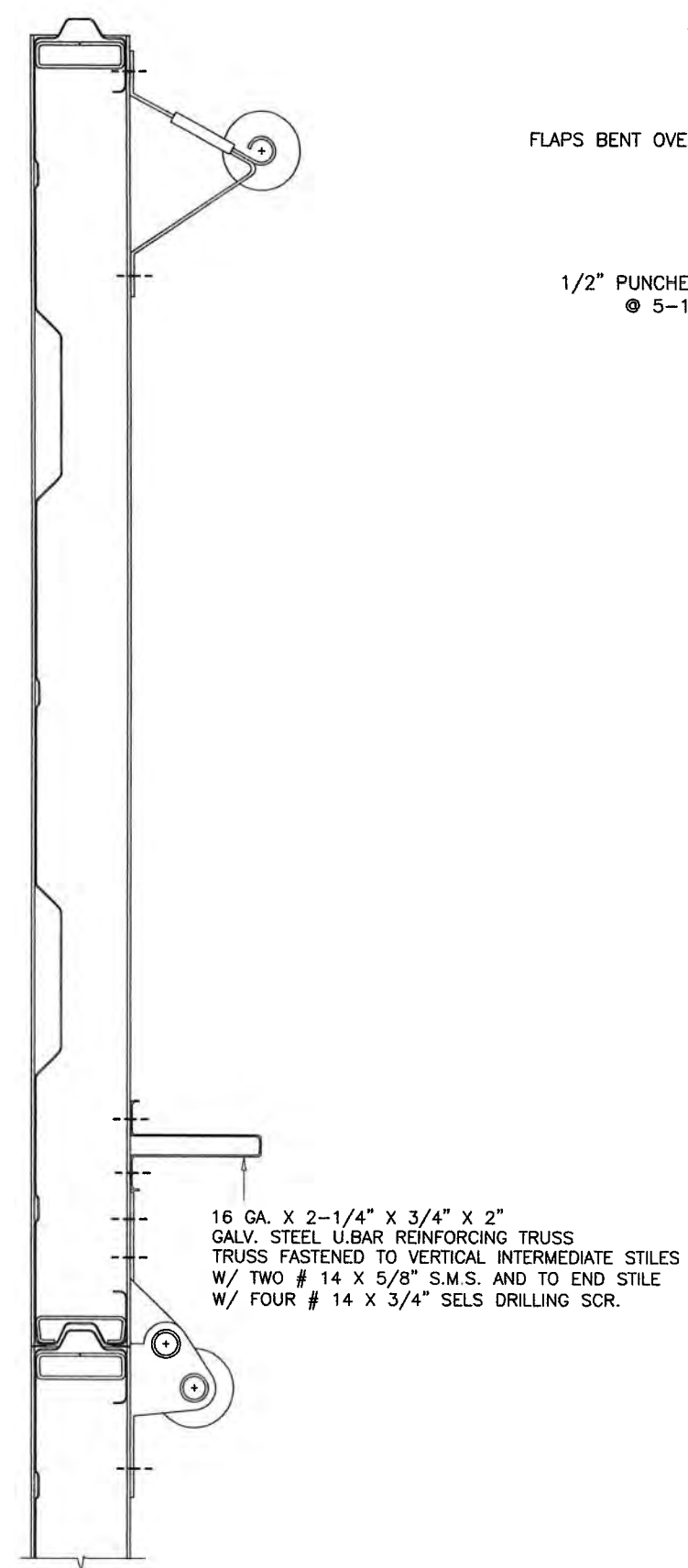

TOP PANEL
REINFORCING

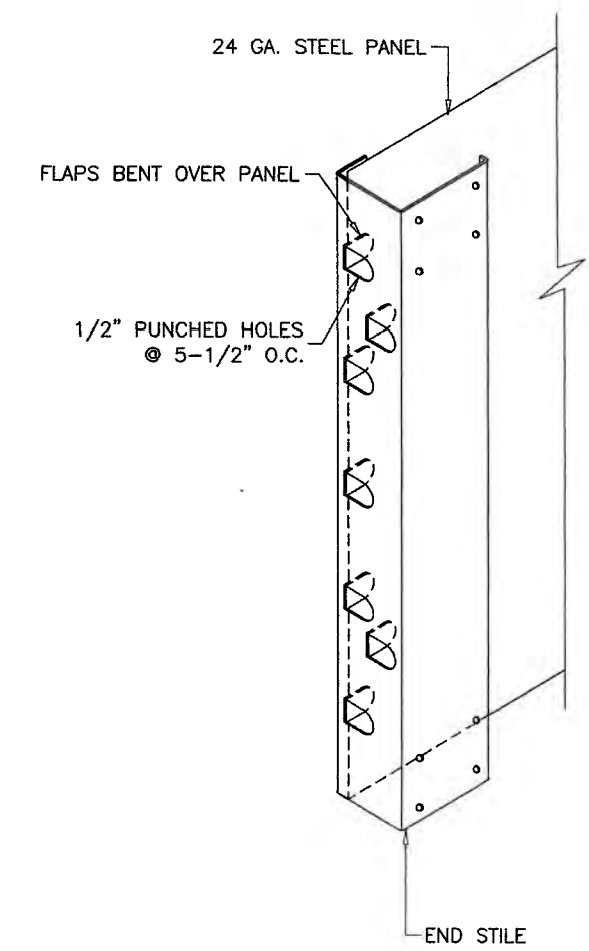

PRODUCT REVISED
as complying with the Florida
Building Code
NOA-No. 20-0901.23
Expiration Date 07/14/2025
By *[Signature]*
Miami-Dade Product Control

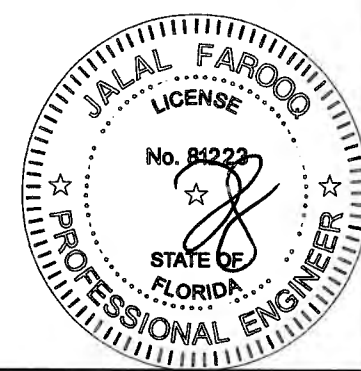

NOV 16 2020

af c
AL-FAROOQ CORPORATION
ENGINEERS & PRODUCT DEVELOPMENT
9360 SUNSET DRIVE, SUITE 220 (C.A.N. 3588)
MIAMI, FLORIDA 33173
TEL. (305) 264-8100 FAX. (305) 262-6978
GARAGE\04-01DAB

STEEL OVERHEAD SECTIONAL GARAGE DOOR
DAB Door Company, Inc.
12195 N.W. 98th Ave.
Hialeah Gardens, Fl. 33018
Tel: (800) 257-2016 Fax: (305) 362-9272

no	date	by	description
D	10.13.11		NO CHANGE THIS SHEET
E	09.16.14		NO CHANGE THIS SHEET
F	03.09.15		BOTTOM SEAL OPTION ADDED
G	10.31.17		UPDATED TO 2017 FBC
H	07.20.20		UPDATED TO 2020 FBC

date: 01-16-04
scale:
dr. by: TARIQ
chk. by:

drawing no.
04-01
sheet 3 of 5

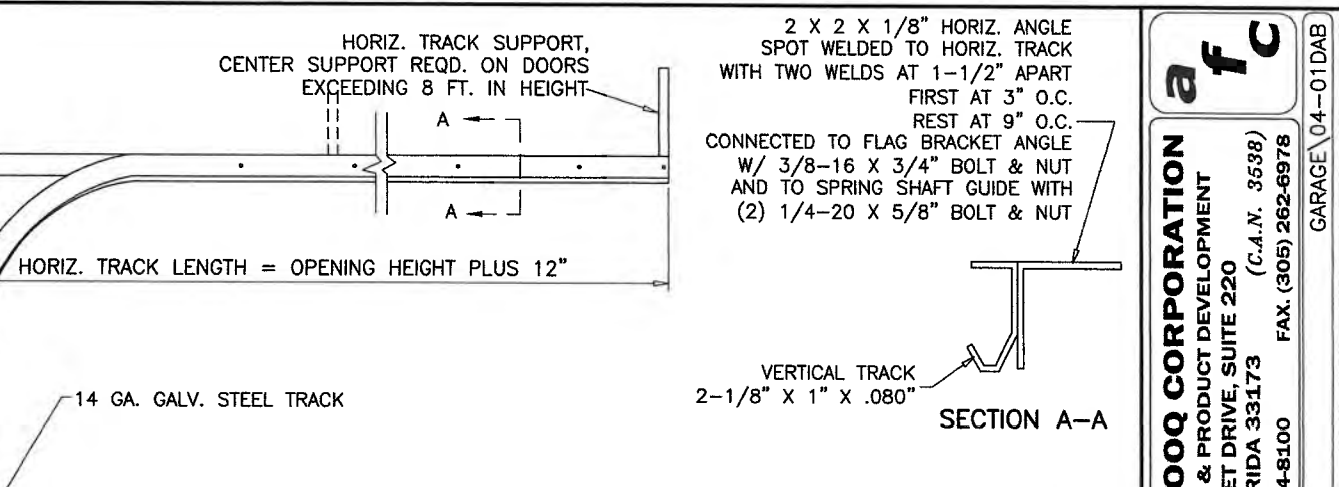
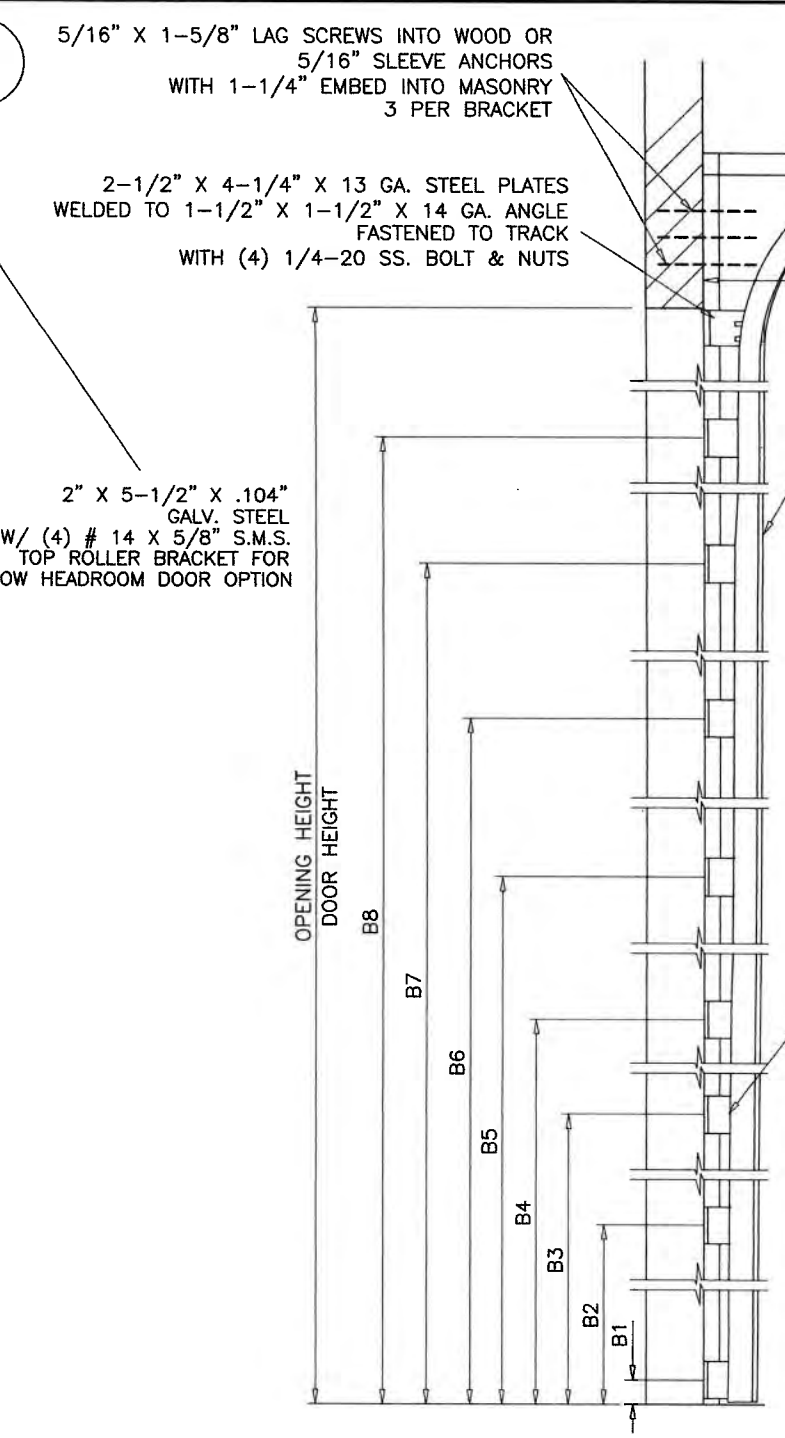
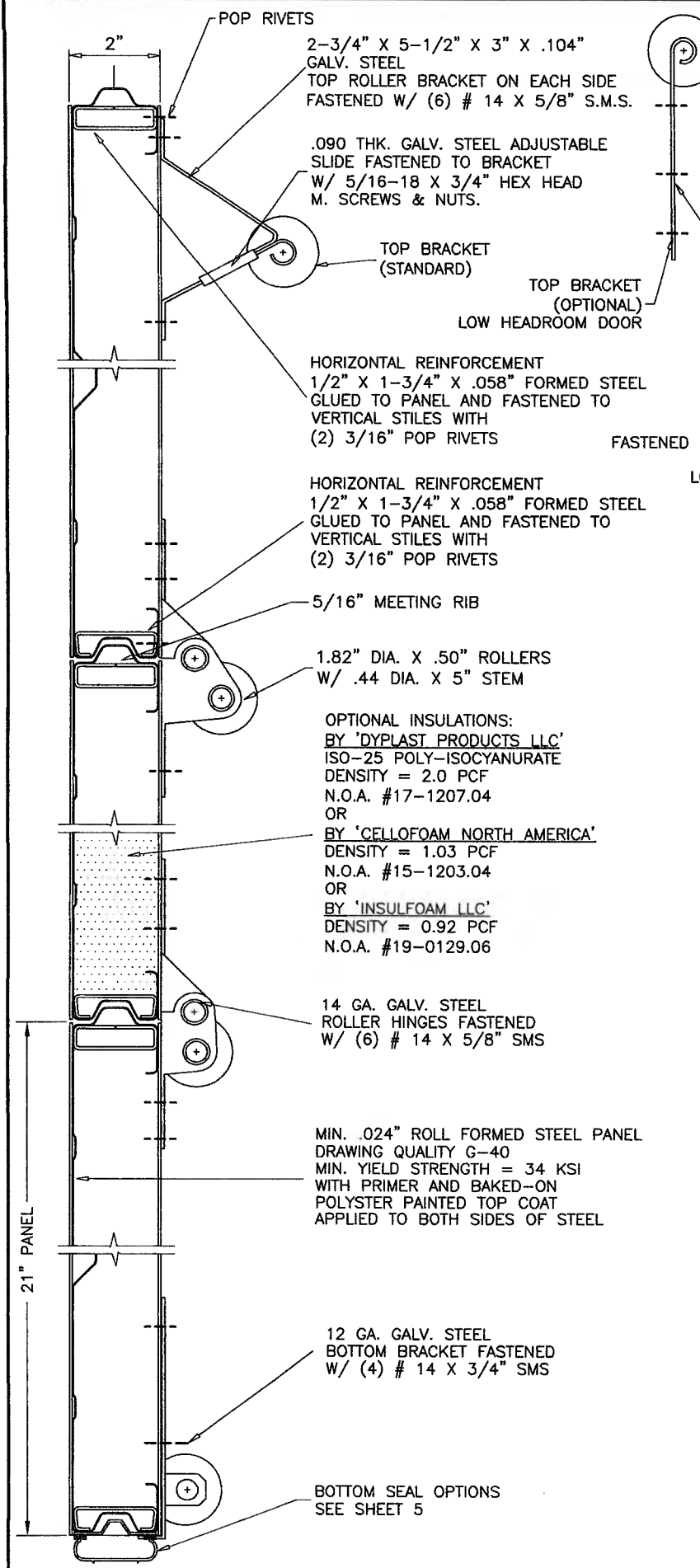

DOOR HEIGHT	* SECTION HEIGHTS					BRACKET PLACEMENTS							
	1ST	2ND	3RD	4TH	5TH	B1	B2	B3	B4	B5	B6	B7	B8
7'-0"	21"	21"	21"	21"	N/A	1" TO 2"	11-3/4"	23"	34"	45"	56"	67"	-
7'-6"	24"	24"	21"	21"	N/A	1" TO 2"	11-3/4"	23"	34"	45"	56"	67"	78-1/4"
7'-9"	24"	24"	24"	21"	N/A	1" TO 2"	11-3/4"	23"	34"	45"	56"	67"	78-1/4"
8'-0"	24"	24"	24"	24"	N/A	1" TO 2"	11-3/4"	23"	34"	45"	56"	67"	78-1/4"

*-SECTIONS ARE NUMBERED STARTING AT THE BOTTOM FOR DOORS MORE THAN 8 FT. HIGH, USE ADDITIONAL TRACK BRACKETS AT 10" O.C.

1.9" X 2.19" X 3.3" X .090" STEEL TRACK BRACKETS CONNECTED TO TRACK WITH (1) 1/4" BOLTS & NUTS.

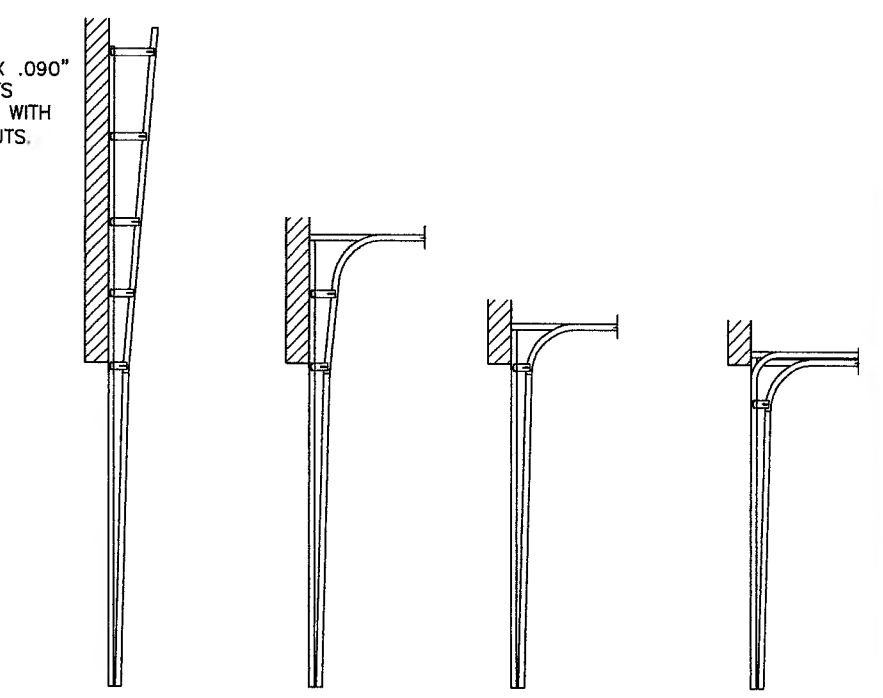

SECTION A-A
SEE SHEET 3 FOR LOCATION OF REINFORCING TRUSSES

PRODUCT REVISED
as complying with the Florida Building Code
NOA-No. 20-0901.23
Expiration Date 07/14/2025
By *[Signature]*
Miami-Dade Product Control

NOV 16 2020

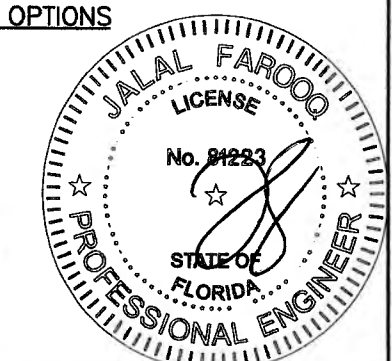

AL-FAROOQ CORPORATION
ENGINEERS & PRODUCT DEVELOPMENT
9360 SUNSET DRIVE, SUITE 220
MIAMI, FLORIDA 33173 (C.A.N. 3538)
TEL. (305) 264-8100 FAX. (305) 262-6978
GARAGE\04-01DAB

STEEL OVERHEAD SECTIONAL GARAGE DOOR
DAB Door Company, Inc.
12195 N.W. 98th Ave.
Hialeah Gardens, FL 33018
Tel: (800) 257-2016 Fax: (305) 362-9272

no	date	description
D	10.13.11	NO CHANGE THIS SHEET
E	09.16.14	GENERAL REVISION
F	03.09.15	BOTTOM SEAL OPTION ADDED
G	10.31.17	UPDATED TO 2017 FBC
H	07.20.20	UPDATED TO 2020 FBC

date: 01-16-04
scale:
dr. by: TARIQ
chk. by:
drawing no. 04-01
sheet 4 of 5

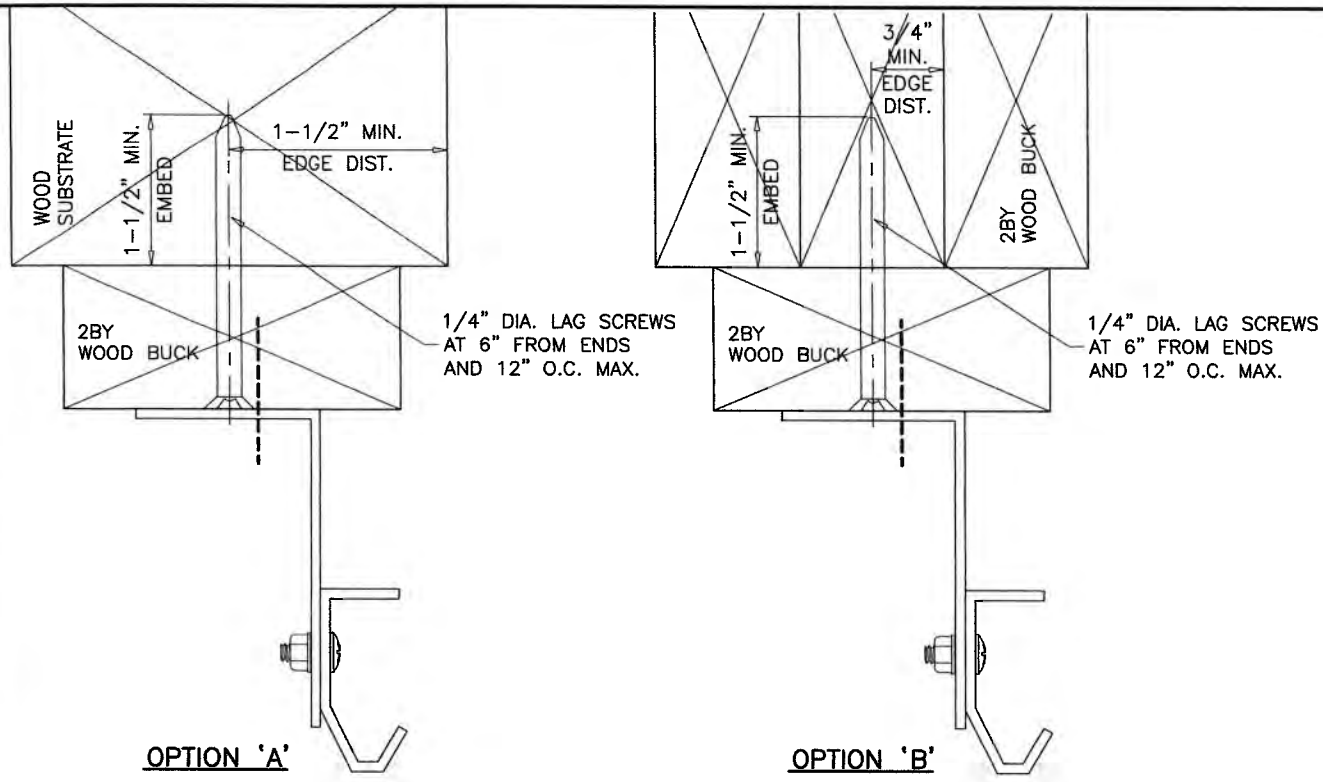

WOOD BUCK CONNECTION TO WOOD SUBSTRATE

THE INSTALLATION METHODS SHOWN ABOVE SHOWS 2X6 SYP WOOD BUCK ATTACHMENT TO WOOD STRUCTURES. IF THESE METHODS ARE FOLLOWED NO ADDITIONAL CALCULATIONS/DESIGN WILL BE REQUIRED FOR DESIGN OF GARAGE DOOR ANCHORAGE. FOR DOOR REPLACEMENT APPLICATIONS WITH NO ENGINEER OF RECORD, INSTALLATION MAY BE VERIFIED AND APPROVED BY THE BUILDING OFFICIAL UPON INSPECTION.

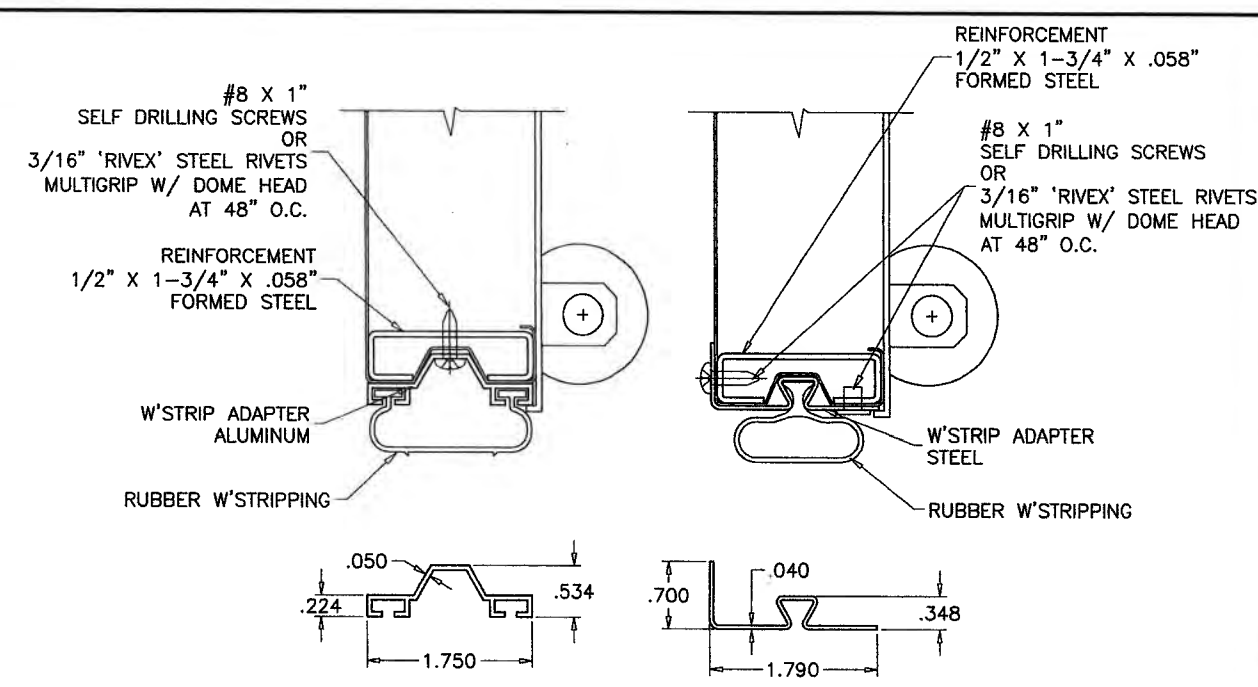

BOTTOM SEAL OPTIONS

ANCHOR SPACING				
ANCHORS	STRUCTURE	EMBED	SPACING	EDGE DIST.
3/8" HLC SLEEVE BY 'HILTI'	CONC.	1-1/4"	8"	2"
3/8" CONFLX BY 'ELCO'	FILLED BLOCK	2"	8"	3-3/4"
3/8" DYNABOLT BY 'ITW'	CONC.	1-1/2"	8"	2-3/4"
3/8" POWER-BOLT BY 'DEWALT'	CONC.	2"	8"	1-7/8"
3/8" SLEEVE-ALL BY 'SIMPSONS'	CONC.	1-1/2"	8"	3"

CONCRETE f'c = 3000 PSI MIN.
C-90 GROUT FILLED BLOCK f'm = 2000 PSI MIN.

WOOD BUCK CONNECTION TO MASONRY

PRESSURE TREATED 2X6 SYP WOOD JAMBS WHICH SHALL BE ANCHORED TO GROUTED REINFORCED MASONRY BLOCK WALL OR CONC. COLUMN WITH

1/4" ULTRACON+ BY 'DEWALT' WITH SPACING OF 8" O.C. INTO GROUT FILLED BLOCK WALL, WITH 2-1/4" MIN. EMBED 9" O.C. INTO 3000 PSI CONCRETE, WITH 1-3/4" MIN. EMBED 2-1/2" MIN. EDGE DISTANCE

1/4" TAPPER BY 'DEWALT' WITH SPACING OF 6" O.C. INTO GROUT FILLED BLOCK WALL, WITH 1-1/2" MIN. EMBED 7" O.C. INTO 3000 PSI CONCRETE, WITH 1-3/4" MIN. EMBED 3" MIN. EDGE DISTANCE

3/8" CONFLX BY 'ELCO' OR 3/8" LDT BY 'ITW' WITH SPACING OF 15" O.C. INTO 3000 PSI CONCRETE, WITH 2-1/2" MIN. EMBED 3" MIN. EDGE DISTANCE

3/8" HLC SLEEVE BY 'HILTI' WITH SPACING OF 9" O.C. INTO 3000 PSI CONCRETE, WITH 1-1/4" MIN. EMBED AND 2-1/2" MIN. EDGE DISTANCE

PREPARATION OF JAMBS BY OTHERS

FOR NEW CONSTRUCTION ENGINEER OF RECORD OR ARCHITECT TO VERIFY ADEQUACY OF SUPPORTING STRUCTURE TO SUPPORT LOADS IMPOSED BY DOOR SYSTEM.

FOR DOOR REPLACEMENT IN RETROFIT BUILDINGS WITH NO ENGINEER OF RECORD, DOOR INSTALLATION MAY BE REVIEWED AND APPROVED BY BUILDING OFFICIAL UPON INSPECTION.

MAXIMUM EXTERIOR(+) LOAD PER JAMB = (12.33' X 60 PSF)/2 = 369.9 Lbs per Ft.
MAXIMUM INTERIOR(-) LOAD PER JAMB = (12.33' X 65 PSF)/2 = 400.8 Lbs per Ft.

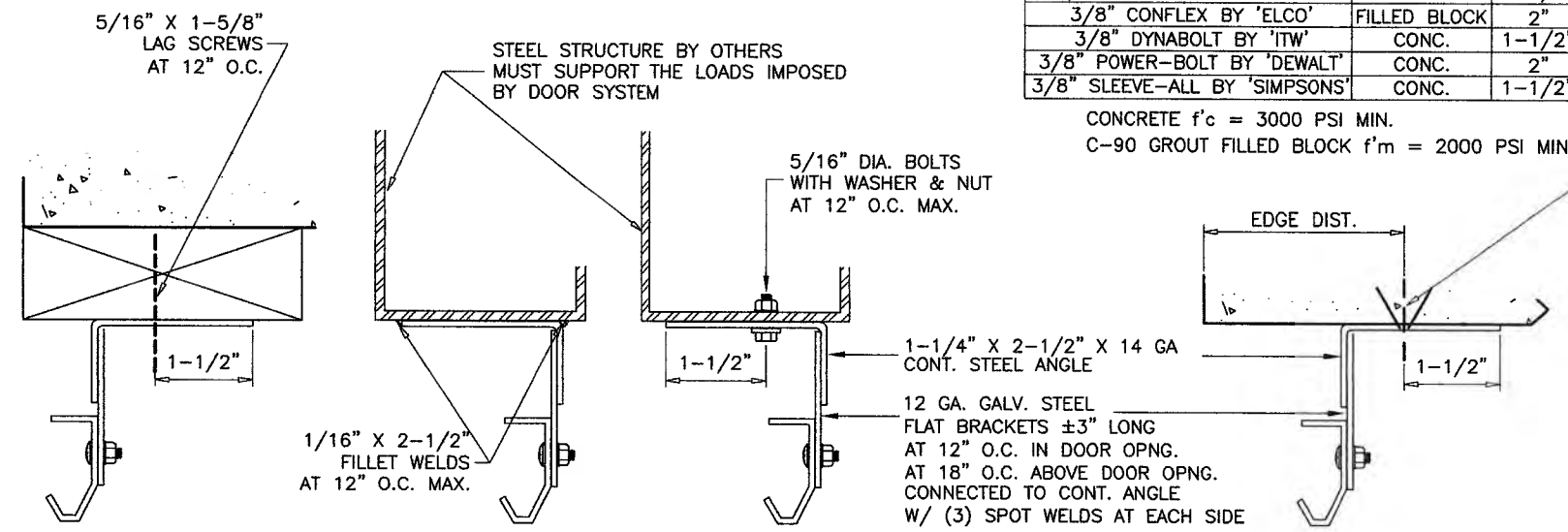

ALTERNATE TRACK INSTALLATION

PRODUCT REVISED

as complying with the Florida Building Code
NOA-No. 20-0901.23

Expiration Date 07/14/2025

By *[Signature]*
Miami-Dade Product Control

NOV 16 2020

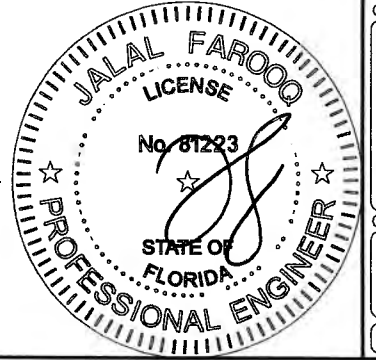

af c
AL-FAROOQ CORPORATION
ENGINEERS & PRODUCT DEVELOPMENT
9360 SUNSET DRIVE, SUITE 220
MIAMI, FLORIDA 33173
TEL. (305) 264-8100 FAX. (305) 262-6978
(C.A.N. 3538)

STEEL OVERHEAD SECTIONAL GARAGE DOOR
DAB Door Company, Inc.
12195 N.W. 98th Ave.
Hialeah Gardens, FL 33018
Tel: (800) 257-2016 Fax: (305) 362-9272

no	date	description
D	10.13.17	NO CHANGE THIS SHEET
E	09.16.14	GENERAL REVISION
F	03.09.15	BOTTOM SEAL OPTION ADDED
G	10.31.17	UPDATED TO 2017 FBC
H	07.20.20	UPDATED TO 2020 FBC

date: 01-16-04
scale:
dr. by: TARIQ
chk. by:

drawing no.
04-01
sheet 5 of 5